



Cortavientos



Características y aplicaciones



Sistema complementario para toldos planos como cerramiento y todas las utilidades de un toldo vertical.

Se compone de un perfil-guía en U y un perfil de carga con un pestillo, el perfil-guía lleva una cinta guarda polvo para evitar el roce entre los dos perfiles.

También puede montar el perfil intermedio que le da rigidez.

Characteristics and applications



System that complements free standing awning as closing. With all the utilities of a vertical awning.

Composed by a guide-profile U and a load profile with a bolt. The guide-profile has a dust cover ribbon to avoid the friction between both profiles.

Also can assembly with intermediate profile that gives it inflexibility.

Caractéristiques et les usages



Système complémentaire pour stores planes comme fermeture et toutes les utilités d'un store vertical.

Il est composé d'un profil-glissière en U et d'un profil de charge avec verrou, le profil-glissière comporte une bande cache-pousière pour éviter le frottement entre les deux profils.

Peut également monter le profil intermédiaire qui lui donne de la rigidité.

Eigenschaften und Anwendungen



Zusätzliches System für flache Markisen wie Abdeckung und alle Verwendungsmöglichkeiten einer vertikalen Markise.

Es besteht aus einer U-Führung und einem Ladeprofil mit Riegel; die Führung hat einen Überzug, der die Reibung zwischen den zwei Profilen vermeidet.

Man kann auch das Zwischenprofil zwecks Straffheit montieren.



Cortavientos

Despiece - Cortavientos parts - Pièces de Cortavientos - Komponenten der Cortavientos

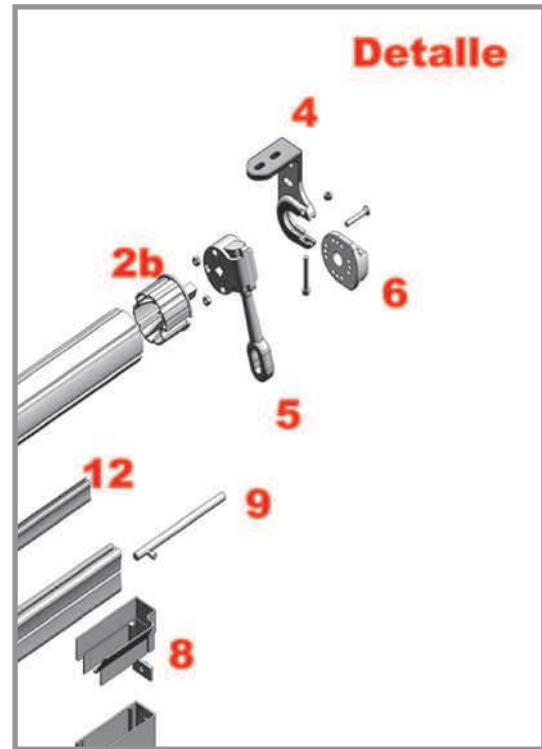
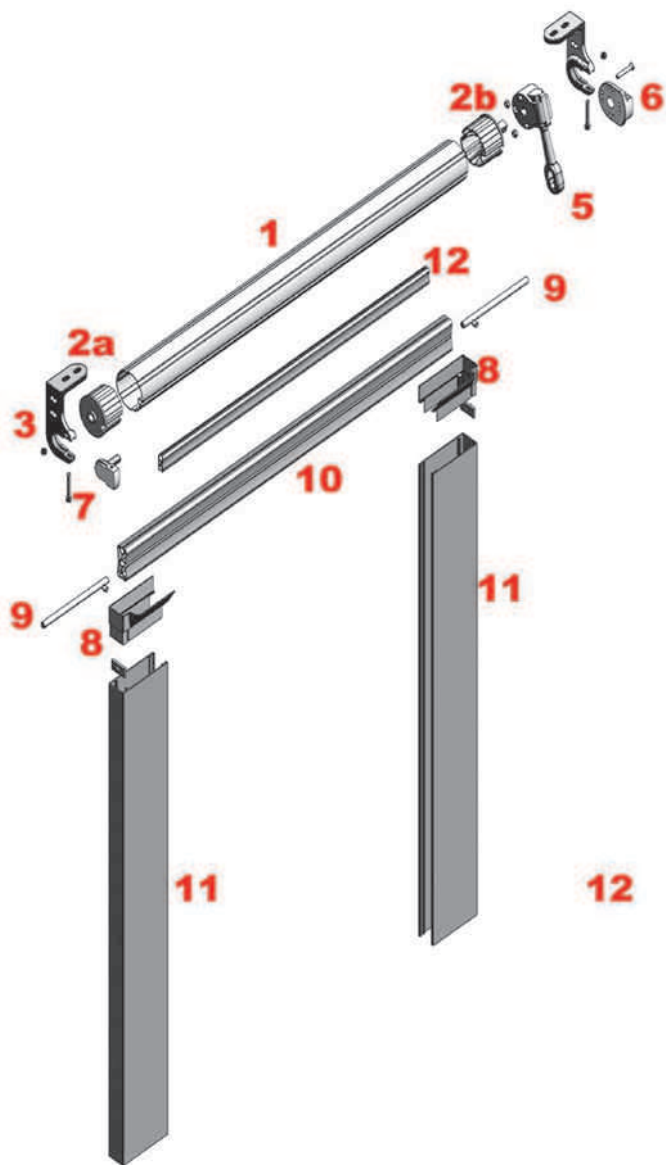

- 1: Tubo de enrollle
- 2a: Casquillo sin punta
- 2b: Casquillo máquina
- 3: Soporte almagro izquierdo
- 4: Soporte almagro derecho
- 5: Máquina
- 6: Acople máquina
- 7: Acople punta
- 8: Embudo
- 9: Pestillo
- 10: Perfil carga cortavientos
- 11: Perfil guía cortavientos
- 12: Perfil intermedio cortavientos



- 1: Rolling tube
- 2a: Valve holder without point
- 2b: Machine valve holder
- 3: Left Almagro support
- 4: Right Almagro support
- 5: Machine
- 6: Machine coupling
- 7: Point coupling
- 8: Funnel
- 9: Lock
- 10: Cut wind load profile
- 11: Cut wind guide profile
- 12: Cut wind intermediate profile



- 1: Tube d'enroulement
- 2a: Douille sans pointe
- 2b: Douille machine
- 3: Support almagro gauche
- 4: Support almagro droit
- 5: Machine
- 6: Raccord machine
- 7: Raccord pointe
- 8: Embout
- 9: Verrou
- 10: Profil Charge Coupe-vent
- 11: Profil Glissière Coupe-vent
- 12: Profil Intermédiaire Coupe-vent



- 1: Tuchwalze
- 2a: Buchse ohne Stift
- 2b: Maschinenbuchse
- 3: Linke Almagrohalterung
- 4: Rechte Almagrohalterung
- 5: Getriebe
- 6: Ankopplung Getriebe
- 7: Stiftankopplung
- 8: Trichter
- 9: Riegel
- 10: Windschutz-Ladeprofil
- 11: Profil Windschutzführung
- 12: Windschutzzwischenprofil

Ref.: 220300__



Juego Soportes Almagro
Almagro Support Kit
Jeu de Supports Almagro
Set Almagrohalterungen

Ref.: 220000__



Juego Embudos Guía Cortavientos
Cut Wind Funnels Kit
Jeu Embouts Glissière Coupe-vent
Set Trichter Windschutzführung

Ref.: 2300_____



Perfil Guía Cortavientos
Cut Wind Guide Profile
Profil Glissière Coupe-vent
Profil Windschutzführung

Ref.: 2310_____



Perfil Carga Cortavientos
Cut Wind Load Profile
Profil Charge Coupe-vent
Windschutzladeprofil

Ref.: 2305_____



Perfil Intermedio Cortavientos
Cut Wind Intermediate Profile
Profil Intermédiaire Coupe-vent
Windschutzzwischenprofil

Ref.: 22040000



Tope Cortavientos
Cut Wind Deadline
Butoir Coupe-vent
Windschutzanschlag

Ref.: 22020000



Pestillo Cortavientos Inox
Inox Cut Wind Lock
Verrou Coupe-vent Inox
rostfr. Windschutzriegel

Ref.: 22010000

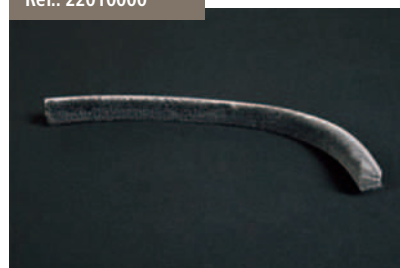

Cinta Guardapolvo
Dust Cover Ribbon
Bande Cache-poussière
Überzug